

SP-Jパイプ 継手詳細図

[外側添接板/溶接80%/縦継ぎ] S=1/10

断面図

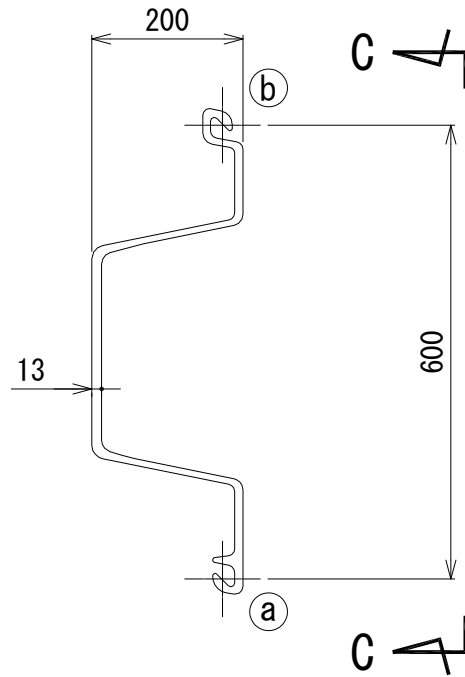

矢視 C-C

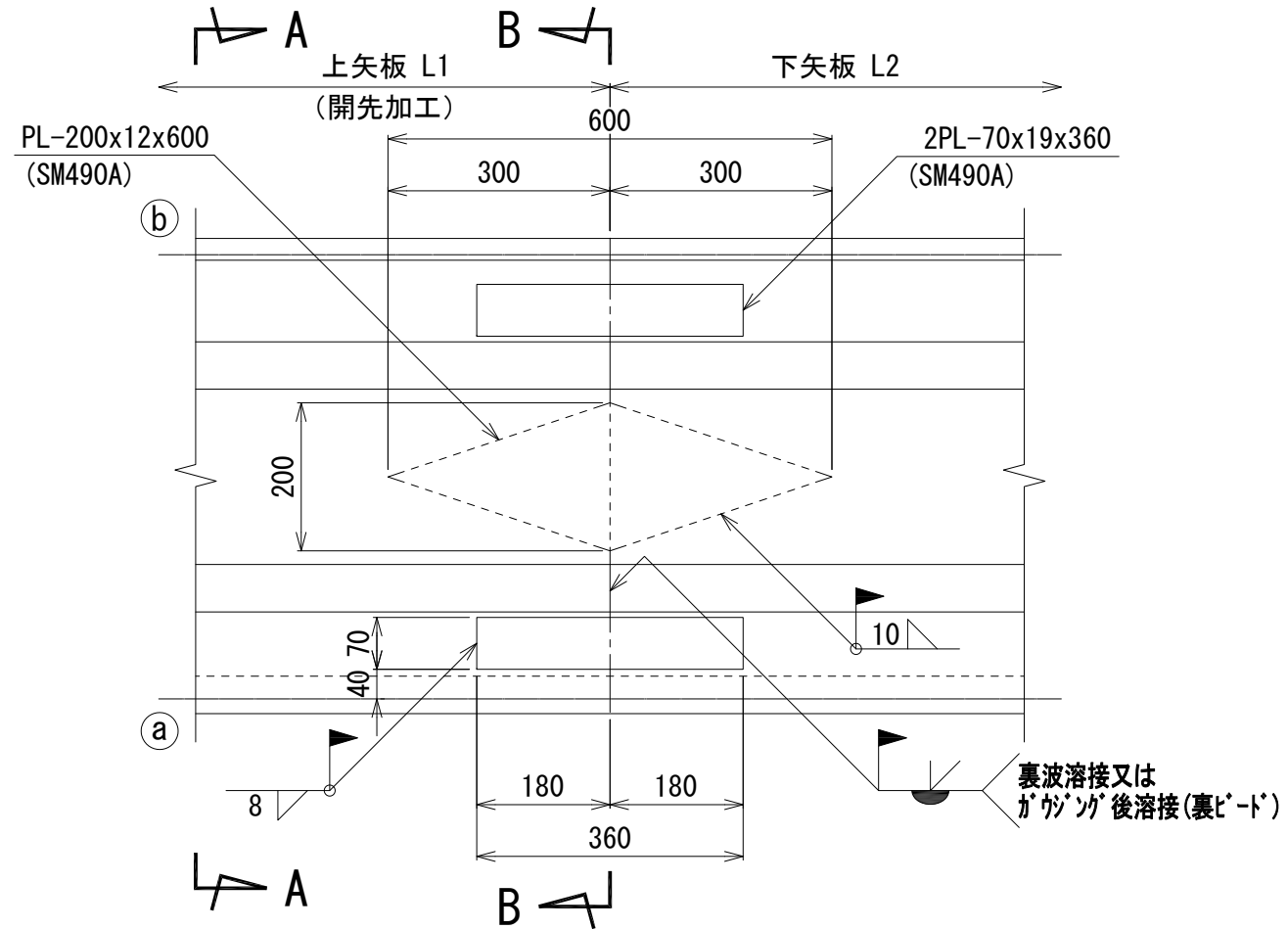

断面図 A-A

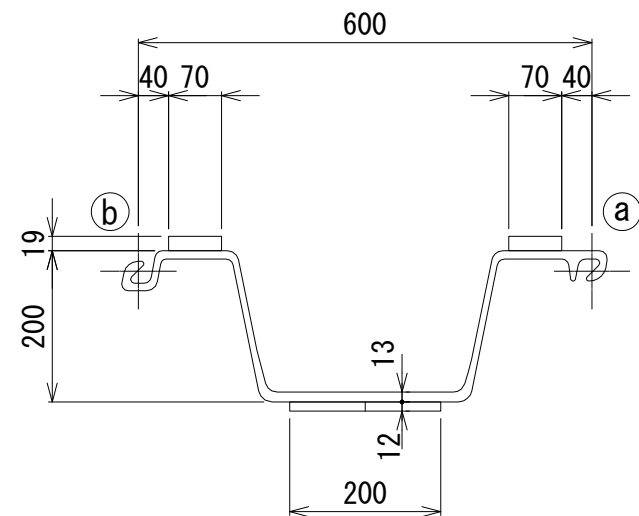

開先加工範囲

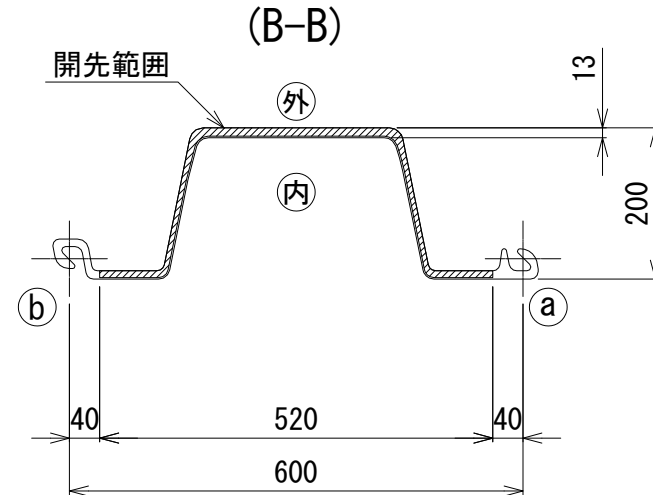

開先形状図 S=1/1

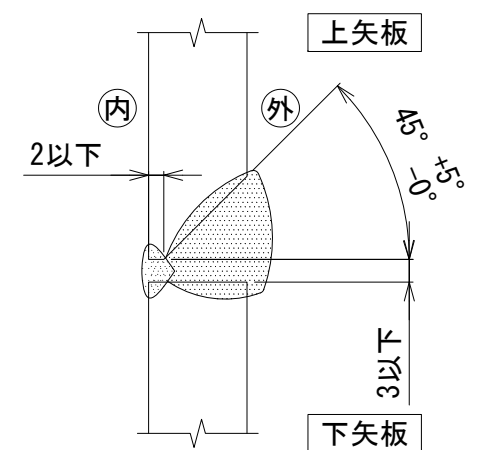

鋼矢板現場溶接継手(外側-縦80%)加工図

(株)エムオーテック